



GEEPLUS

Push Pull Solenoid size 401

Device drawn in energised condition
 plunger options: conical (401C) / flat (401F)
 Life Expectancy (cycles): >2M (-P), >10M (-PE)

Available mechanical options:
 M: metric thread
 F: SAE thread

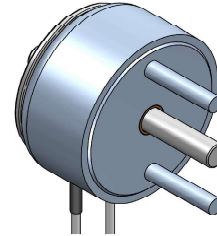
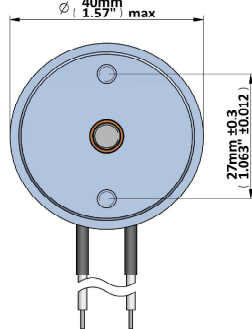
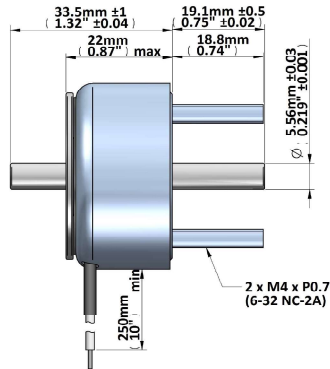

Mass 200g
 Plunger (C) 60g
 Plunger (F) 40g
 Leadwires 24AWG, UL1430

force / stroke 401C
 stroke (inch)

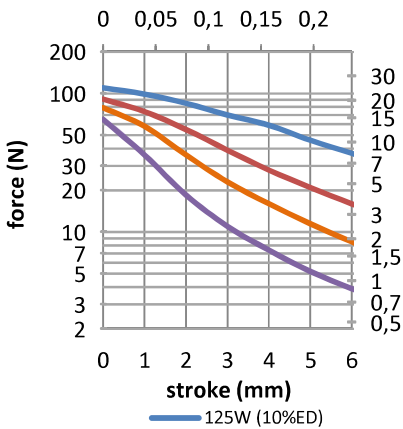

force / stroke 401F
 stroke (inch)

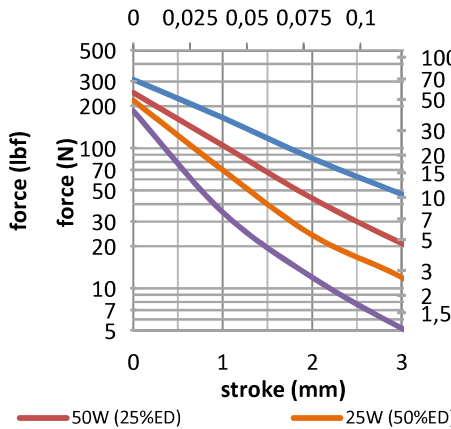

response time 401C
 stroke (inch)

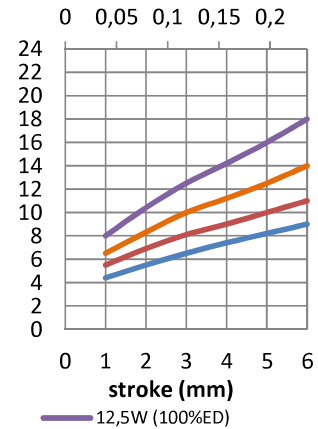

Data at 20°C, device connected to heatsink 160x160x3mm aluminum

duty cycle = $\frac{\text{"on" time}}{\text{"on" time} + \text{"off" time}} \times 100\%$		100% cont.	50% or less	25% or less	10% or less	
Max. "on" time in seconds		∞	100	36	9	
watts at 20°C		12,5	25	50	125	
ampere-turns at 20°		714	1000	1425	2250	
AWG no.	resistance	number of turns	volts DC			
	$\Omega \pm 10\%$ (at 20°C)					
25	3,50	384	6,6	9,5	13	21
26	5,67	486	8,4	12	17	27
27	8,76	600	11	16	22	35
28	13,8	748	13	18	26	42
29	22,6	975	17	23	33	52
30	34,8	1190	21	30	42	67
31	56,7	1520	27	38	54	85
32	88,3	1908	35	49	70	110
33	138	2360	43	60	86	138
34	216	2904	53	75	106	168
35	351	3725	67	95	132	213
36	480	4000	85	119	169	268
37	720	4950	105	147	210	332
38	1150	6200	132	185	264	-
39	1920	8350	166	232	332	-
40	3000	10000	210	300	-	-

Insulation Resistance >100MΩ, 500VDC Megger
 Class E (120°C) insulation class

Dielectric Strength 1000VAC, 50/60Hz, 1 minute

Geeplus reserves the right to change specifications without notice

www.geeplus.com