



GEEPLUS

VM6340

P_{100} is the continuous (100% ED) excitation power at which the coil attains temperature T_{max} with the part mounted to a massive heatsink at 20°C

P_{100} 24 W

T_{max} 130 °C

Total Mass 750 g

Coil Mass 40 g

Model No.	Resistance R_{20}	Inductance	Force Constant	Velocity Constant	Current I_{100}
VM6340-400	2.5 Ω	1.3 mH	12 N/A	12 Vs/m	2.6 A
VM6340-250	15.3 Ω	7.8 mH	29 N/A	29 Vs/m	1.1 A
VM6340-190	45 Ω	20.0 mH	51 N/A	51 Vs/m	0.6 A

	Max 'ON' time	Peak Force
100% ED	∞	31 N
50% ED	65 s	46 N
25% ED	12 s	65 N
10% ED	3 s	104 N

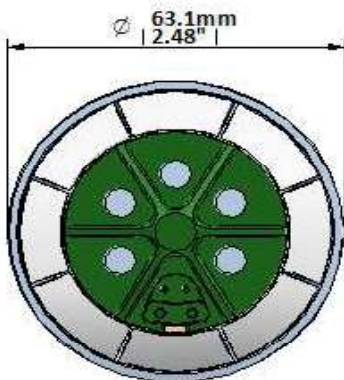
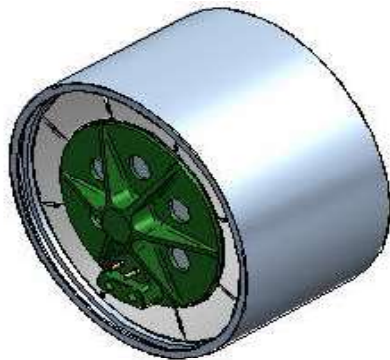

INCREASING STROKE 0mm

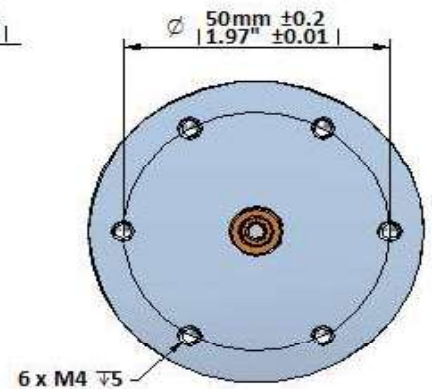
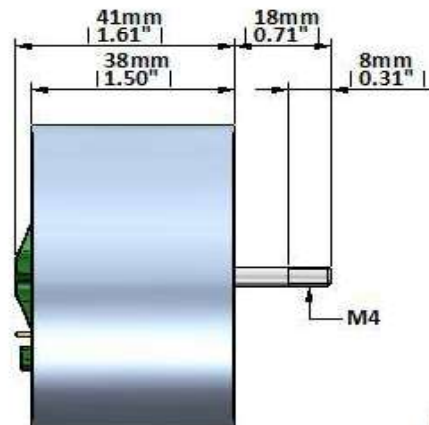

Force (N) vs Displacement (mm)

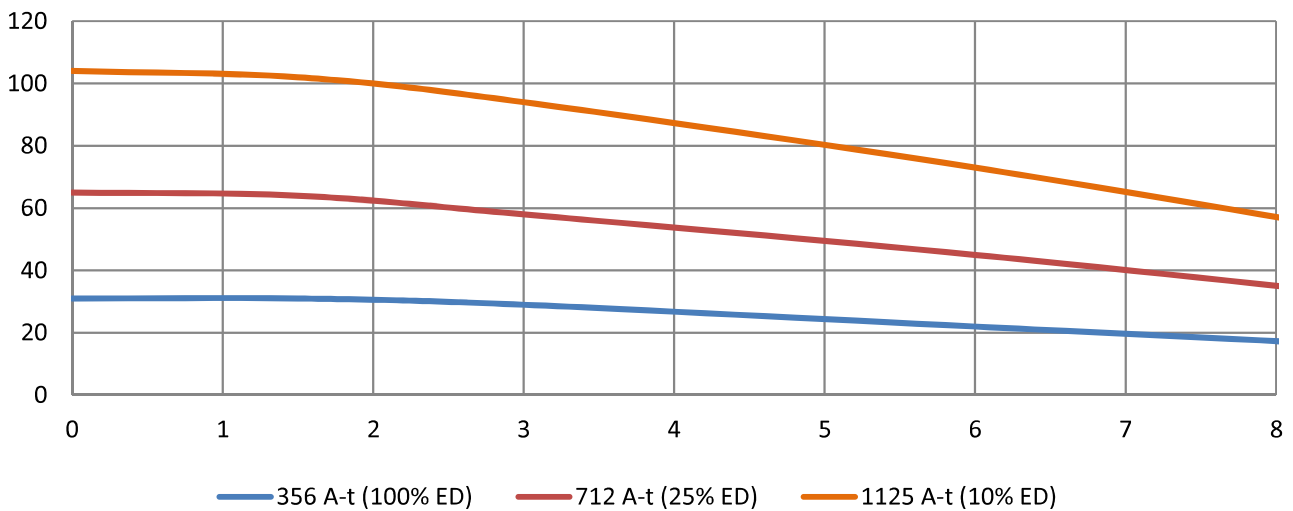

Geeplus reserves the right to change specifications without notice

www.geeplus.com